



perma Lubrication Systems for
Conveyors

The Expert in Lubrication Solutions

perma



24 / 7 Nonstop lubrication

Conveyor systems are used in all types of industries and in different environments. From the extreme weather of the quarrying industry to the hygienically sensitive conditions of the food industry, conveyor reliability is always directly related to profitability and efficiency. Since a conveyor system is a critical link in a company's ability to move its products in a timely fashion, any disruption can be costly. Proper lubrication is critical in helping to reduce component wear and contamination. However, some of the toughest lubrication problems are found in conveyor lines. Maintenance teams are presented with long walking distances, ladders and stairs. Many lubrication points are located at hard to reach or dangerous places and cannot be properly lubricated or are overlooked completely.

Since 1964, automatic lubrication systems from perma-tec are successfully being used worldwide for the lubrication of conveyor lines. They are economical, meet technical demands and drastically improve workplace safety.

→ Challenges

Conveyor systems face some of the toughest lubrication problems. To prevent equipment downtime, conveyors require optimal lubrication despite extreme operating conditions (dust, dirt, water, weather, strong vibrations, long walking distances, etc.)

- **Dirt and water must be kept from entering lubrication points**
- **Lubrication points must receive the right lubricant, in small amounts, at regular intervals - without the need to shut down the system**



Compliance with manufacturer recommended re-lubrication intervals takes up a lot of maintenance time. But improper lubrication causes premature pulley and bearing damage and eventually shuts down a complete line.

- **Unscheduled downtime and costly repairs as a result of premature wear**



Lubrication points in difficult to reach and dangerous areas can prove fatal to the life of a worker.

- **High risk of workplace accidents**



Lubrication points on conveyors

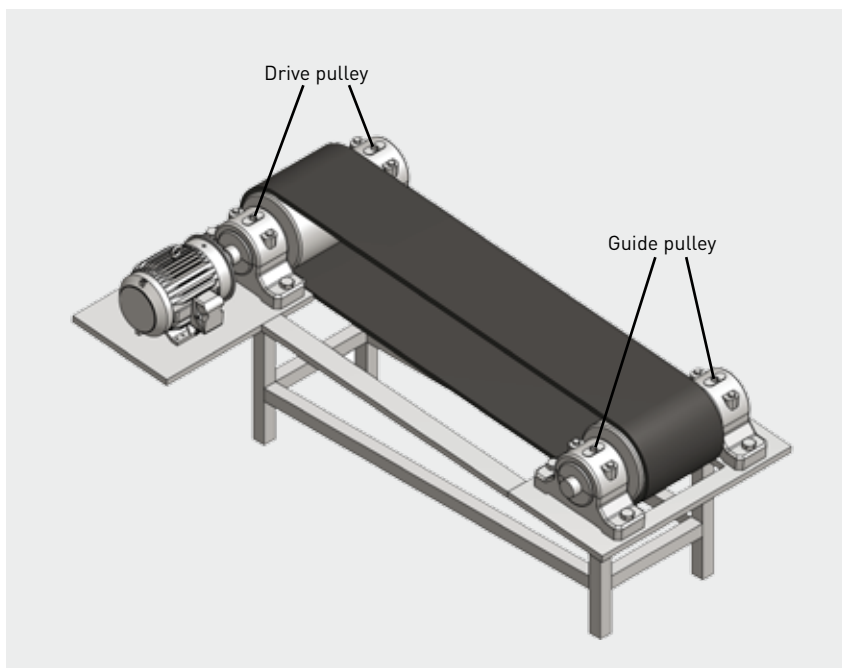

Conveyor model with 4 lubrication points

Risk of bearing damage from contaminated lubrication points

→ Solutions

perma CLASSIC / perma FUTURA

- Housing: perma CLASSIC - metal / perma FUTURA - transparent plastics
- Electrochemical / grease and oil
- Operating temperature: 0 °C to +40 °C
- Discharge period at +20 °C with SF01: 1, 3, 6 or 12 months
- Pressure build-up: Max. 4 bar
- Lubricant volume: 120 cm³

→ perma CLASSIC: Metal housing = ideal for rough environments

→ perma FUTURA: Corrosion proof = ideal for hygienically clean environments



perma STAR VARIO

- Housing: Transparent plastics
- Electromechanical / grease and oil / temperature independent
- Operating temperature: -10 °C to +60 °C
- Discharge period: 1, 2, 3, ... 12 months
- Pressure build-up: 6 bar
- Lubricant volume: 60 cm³, 120 cm³, 250 cm³

→ One drive unit can be used with three different cartridge sizes



→ Benefits

- Reduces premature wear
- Minimizes equipment downtime
- Improves workplace safety

Product characteristics	Advantages	Benefits
economical aspects		
perma CLASSIC / perma FUTURA Fully automatic lubrication at low cost →	- Reliable lubrication for normal ambient temperatures	- Reduced maintenance costs - Higher equipment availability
perma STAR VARIO Separate drive unit Variable discharge periods Exact discharge →	- Reusable drive unit - Ideal for high grade lubricants - Precise and customized discharge	- Short ROI due to reduced follow-up costs - Optimized lubrication saves lubricant costs - Less equipment downtime, lower maintenance costs
technical aspects		
perma CLASSIC Metal housing Color coded activator screws →	- Simple activation - Supply of fresh, clean lubricant in harsh operating conditions - Robust housing	- Easy to install and use - Can withstand impacts and knocks - Works under water - Works in any position
perma FUTURA Transparent non-corrosive plastic housing →	- Meets hygienic and environmental regulations - Plastic housing shows fill level	- Can be used in areas which are hygienically sensitive - Visual fill level control
perma STAR VARIO Battery operated drive system →	- Higher pressure output for remote mounting - 3 different sizes for one drive unit - LED alert system shows operating status	- Fast, safe mounting with tubes at hard to reach lubrication points - More flexibility with one system - Provides quick function control for maintenance operator
For all perma lubrication systems Special accessories / connection parts →	- Extensive range of accessories and connection parts	- Flexibility and easy installation
workplace safety aspects		
perma CLASSIC / FUTURA Ex-proof certification →	- Can be used in areas where explosive atmospheres may occur	- Safe and reliable lubrication in dangerous areas
perma STAR VARIO Remote mounting possible →	- Automatic lubrication of hard to access lubrication points possible - Remote mounting away from dangerous lubrication points	- Increases workplace safety - Minimizes the risk of maintenance accidents

perma lubrication systems for conveyors

perma products have been used successfully on conveyor lines worldwide. They guarantee reliable automatic re-lubrication for conveyors in all types of industries and environments.

perma automatic lubrication systems - we meet your needs:

- 24-hour operation
- Simple installation
- Requires little mounting space
- Tough systems: battery operated or machine controlled
- Customized supply of fresh lubricants to lubrication points

perma is the most trusted partner worldwide for all industries:

- Global market leader for automatic single-point lubrication systems
- Largest product range in the market
- Many well-known satisfied customers
- Field-tested accessories for every perma lubrication system
- Product training, expert advice and consultation
(please contact your local supplier)



Applications for perma products

Bagging equipment

Electric motors

Transport systems

Sliding guides

Belt pretensioners

Chain drives

Paint finishing systems

Linear drive systems

Mills/crushers

Open gears

Presses

Escalators

Storage equipment

Silos

Blowers & Fans

Pumps

Do you have any questions about perma products for conveyor systems?

Please visit our website or contact your local supplier. We will gladly send you our extensive catalogue for more detailed information.

perma-tec GmbH & Co. KG
Hammelburger Str. 21
97717 EUERDORF
GERMANY

info@perma-tec.com
www.perma-tec.com